

## Gear Tipper Type **TGD**

LOADING POSITION

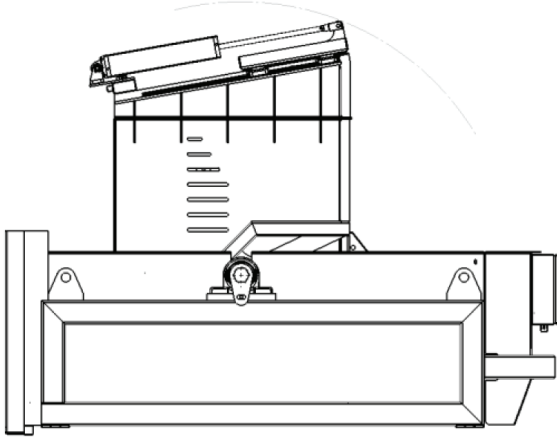

UNLOADING POSITION

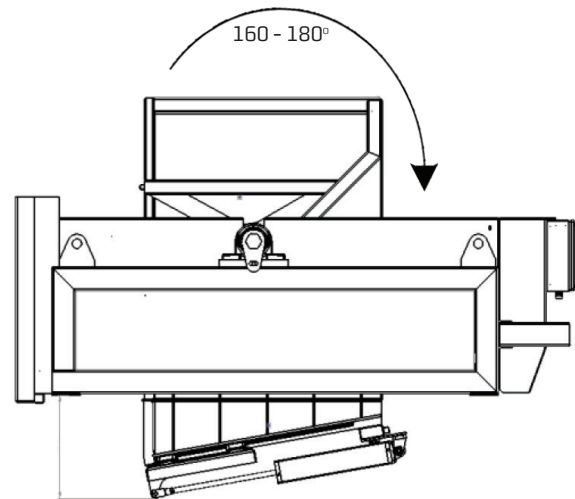

APPLICATION EXAMPLE

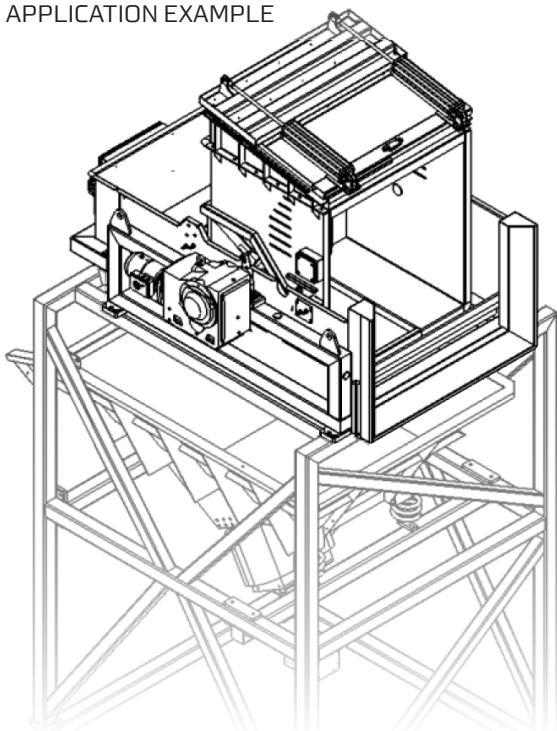

CONTAINER SIZE

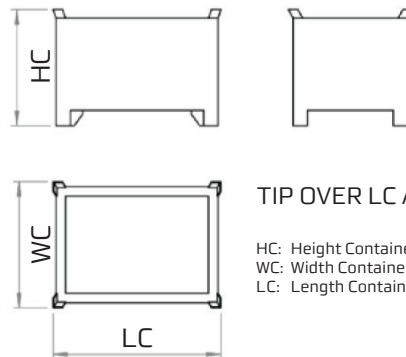

TIP OVER LC AXIS

HC: Height Container  
WC: Width Container  
LC: Length Container

TYPE	MAX. LOAD CAPACITY (KG)	CONTAINER LENGTH LC (mm)	CONTAINER WIDTH WC (mm)	CONTAINER HEIGHT HC (mm)
<b>TGD100</b>	1000	500 - 750	500 - 800	1000
		750 - 1000		
		1000 - 1250		

SKAKO VIBRATION retains all rights to change or improve the above specifications without notice.

3-10-2017

Please contact us for further information regarding exact dimensions and installations.