

Enclosed Vibratory Feeder Type **FCE-4NL** with Electromagnetic Vibrator

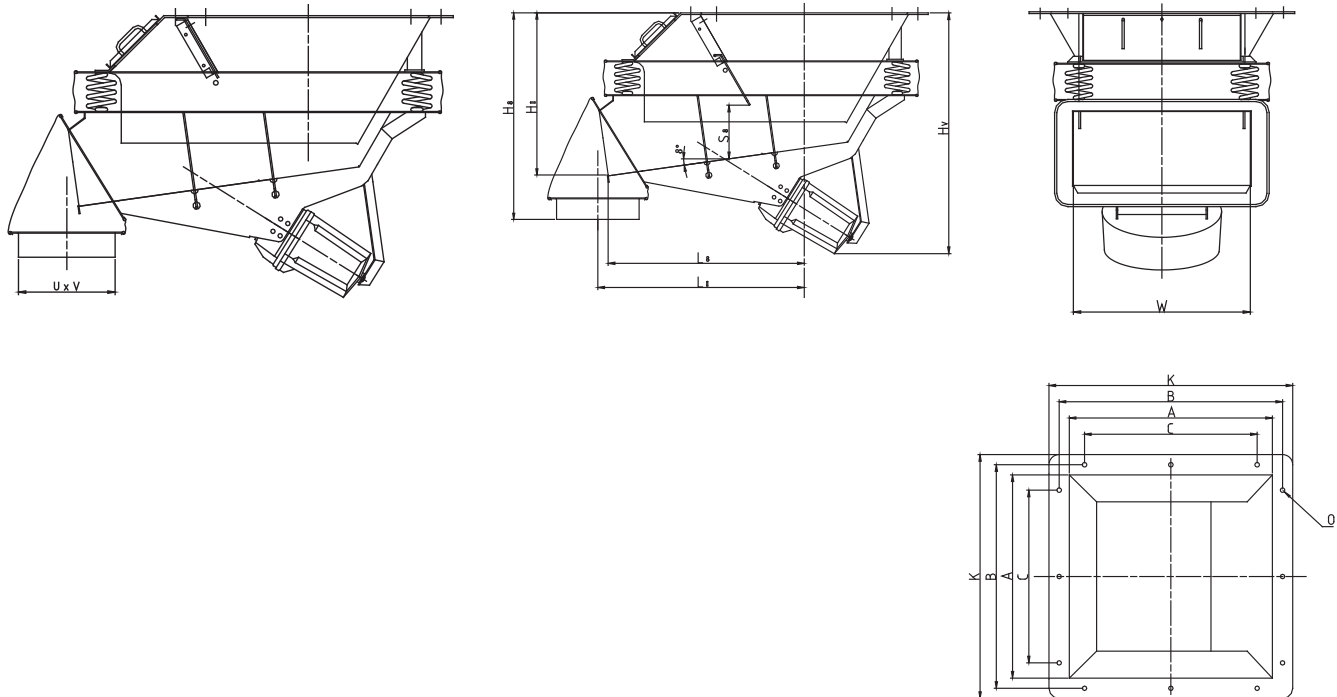

Feeder Size W/L ₀	Capacity m ³ /h 2)	Dimensions trough Profile (mm)			Vibrator Type 1)	Weight kg Excl. wear liner	Installation Requirements (mm)										Diameter (Ø)	Quantity (Q)	UxV
		Width (W)	Height (H)	Wear Lining 3)			L _c 4)	H ₀	H _v	L ₀	H ₀	S ₀	A	B	C	K			
040/0050	37	400	160	3	8D	95	500	500	630	480	385	210	500	580	450	650	18	8	200x460
040/0100	50	400	160	3	20D	145	1000	570	730	950	450	210	500	580	450	650	18	8	200x460
056/0071	85	560	225	4	20D	220	735	710	860	680	560	360	710	800	610	870	22	8	280x620
056/0125	90	560	225	4	50D	325	1250	840	1020	1180	660	360	710	800	610	870	22	8	280x620
080/0100	190	800	315	5	50D	475	1000	1000	1170	950	790	450	1000	1100	2x425	1200	22	12	400x900
080/0160	205	800	315	5	100D	670	1600	1100	1340	1550	880	450	1000	1100	2x425	1200	22	12	400x900
100/0125	290	1000	400	5	100D	875	1250	1220	1350	1190	920	520	1250	1400	2x525	1490	27	12	500x1100
100/0200	300	1000	400	5	2x100D	1450	2000	1230	1650	1900	1030	520	1250	1400	2x525	1490	27	12	500x1100
125/0160	380	1250	500	5	2x100D	2490	1600	1600	1920	1520	1310	770	1600	1750	2x650	1900	27	12	620x1350

05-01-2015

- 1) See appropriate data sheets for vibrators and controllers.
- 2) The capacities stated are indicative for naturally moist sand 0-3 mm. Be aware that the capacities are stated in m³/h.
- 3) In feeders with steel plate wear liners, capacity is reduced by approx. 25%.
- 4) L_c dimensions are valid for naturally moist sand 0-3 mm.
For coarse materials L_c is increased by 50-100 mm.

Please contact us for further information regarding exact dimensions and installations.
SKAKO Vibration retains all rights to change the above specifications without notice.

Enclosed Vibratory Feeder Type **FCE-4NL** with Electromagnetic Vibrator

Feeder capacity can be regulated in 2 ways:

By adjusting the trough gate

Adjusting the trough gate allows a continuously variable regulation of the depth of material on the vibratory trough.

By means of the control

By means of the control, it is possible to achieve an infinite variation from 0% to 100% of the preset capacity.

Feeder size is chosen on the basis of:

Primarily, capacity in cubic metres per hour (m³/h)

Bulk densities in the range 0,3-5t/m³ have an insignificant influence on the capacity of feeders with electromagnetic vibrators.

Secondarily, particle size and material characteristics

Normally the indicated capacities are achievable when particle sizes are no larger than 1/10th of the trough width.

The feeders are able to handle considerably coarser materials, but with reduced capacity.

To avoid jamming, materials containing lump sizes larger than 1/3rd of the maximum gate opening should only be handled in larger feeders.

Feeder Design:

All standard feeder sizes are available in a short version; the smaller sizes are also available in a long version for materials with a low slope angle.

At 8° downslope the following minimum slope angles at maximum and minimum gate opening are obtained:

Short feeders: approximately 40° and 25°, respectively.

Long feeders: approximately 25° and 15°, respectively.

Vibratory troughs may be lined with e.g rubber, PEHD, PUR, steel etc. The type of liner is selected according to the nature of the material to be handled (e.g sticky, corrosive or very abrasive).

Feeders with no wear lining are appropriate for proportioning from e.g rarely emptied silos. The material may be slightly to moderately abrasive, e.g vegetables, gravel and sand.

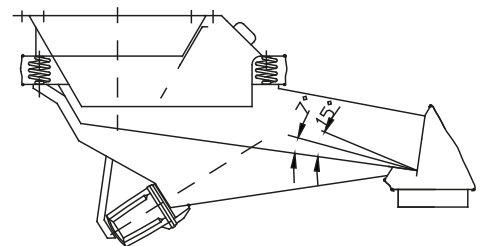
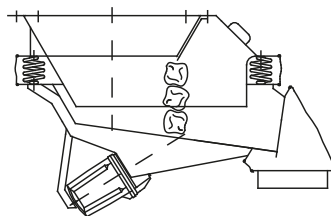
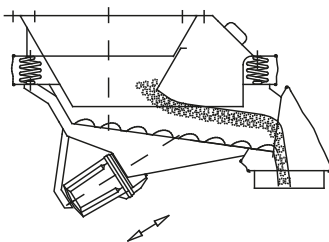
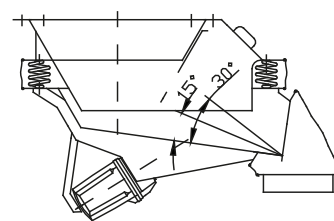
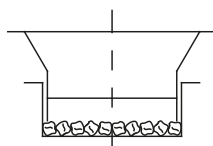
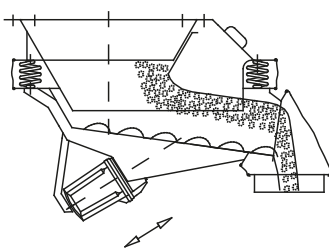

Please contact us for further information regarding exact dimensions and installations.
SKAKO Vibration retains all rights to change the above specifications without notice.