

## Screen Type **S2S**

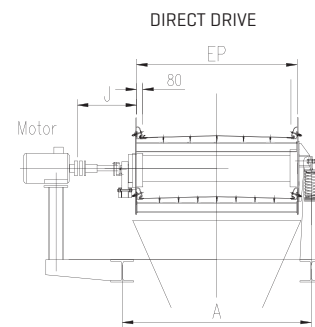
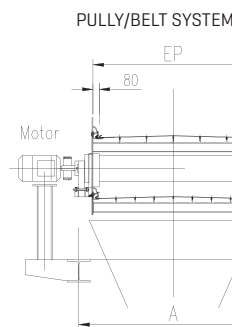
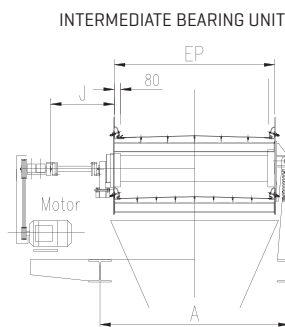
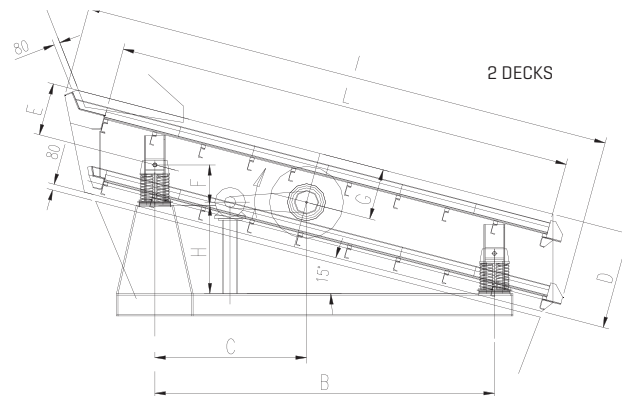

**INSTALLATION REQUIREMENTS (mm)**

TYPE	WEIGHT	EP	A	B	C	D	E	F	G	H	I	J	L	SCHAFT
S2S 125/0400 M1I	2800	1250	1625	3000	1500	1300	708	480	680	803	4995	680	4000	CH 90
S2S 125/0500 M1I	3110	1250	1625	3480	1500	1300	708	480	680	803	6000	680	5000	CH 90
S2S 160/0400 M1I	3390	1600	1975	3000	1506	1300	708	480	680	803	5000	680	4000	CH 90
S2S 160/0450 M1I	3860	1600	1975	3000	1260	1300	708	480	680	803	5500	790	4500	CH 100
S2S 160/0500 M1I	4114	1600	1975	3480	1502	1300	708	480	680	932	6000	790	5000	CH 100
S2S 180/0450 M1I	4130	1800	2175	3000	1260	1300	708	480	680	803	5500	790	4500	CH 100
S2S 180/0500 M1I	4380	1800	2175	3480	1502	1300	708	480	680	932	6000	790	5000	CH 100
S2S 180/0600 M1I	5056	1800	2175	4445	1985	1300	708	480	680	1191	7000	790	6000	CH 100
S2S 200/0500 M1I	5260	2000	2375	3480	1502	1300	708	480	680	932	6000	790	5000	CH 120
S2S 200/0600 M1I	5830	2000	2375	4445	1985	1300	708	480	680	1191	7000	825	6000	CH 140
S2S 200/0700 M1I	6655	2000	2375	5410	2468	1600	1000	480	680	1450	8100	825	7000	CH 140
S2S 220/0600 M1I	7040	2200	2575	4445	1985	1600	1000	480	680	1191	7100	825	6000	CH 140
S2S 220/0700 M1I	7550	2200	2575	5410	2468	1600	1000	480	680	1450	8100	825	7000	CH 140
S2S 250/0600 M1I	8060	2500	2875	4445	1985	1600	1000	480	680	1191	7100	825	6000	CH 140
S2S 250/0700 M1I	8600	2500	2875	5410	2468	1600	1000	480	680	1450	8100	825	7000	CH 140
S2S 280/0700 M1I	12390	2800	3500	4500		2000	540	540	1000	1215	8100	790	7000	2 CH 120
S2S 280/0800 M1I	14510	2800	3500	5500		2000	540	540	1000	1474	9100	1015	8000	2 CH 160
S2S 300/0800 M1I	14840	3000	3700	5500		2000	540	540	1000	1474	9100	1015	8000	2 CH 160

SCHAFT	MOTOR	SCHAFT	MOTOR	SCHAFT	MOTOR
CH 90 - 750 tr/mn	15 Kw	CH 120 - 750 tr/mn	22 Kw	2 CH 120 - 750 tr/mn	45 Kw
CH 90 - 1000 tr/mn	11 Kw	CH 120 - 1000 tr/mn	18,5 Kw	2 CH 120 - 1000 tr/mn	37 Kw
CH 90 - 1500 tr/mn	7,5 Kw	CH 120 - 1500 tr/mn	11 Kw	2 CH 120 - 1500 tr/mn	22 Kw
CH 100 - 750 tr/mn	18,5 Kw	CH 140 - 750 tr/mn	30 Kw	2 CH 160 - 750 tr/mn	60 Kw
CH 100 - 1000 tr/mn	15 Kw	CH 140 - 1000 tr/mn	22 Kw	2 CH 160 - 1000 tr/mn	45 Kw
CH 100 - 1500 tr/mn	9 Kw				

22-05-2013

Please contact us for further information regarding exact dimensions and installations.  
**SKAKO Vibration** retains all rights to change the above specifications without notice.